

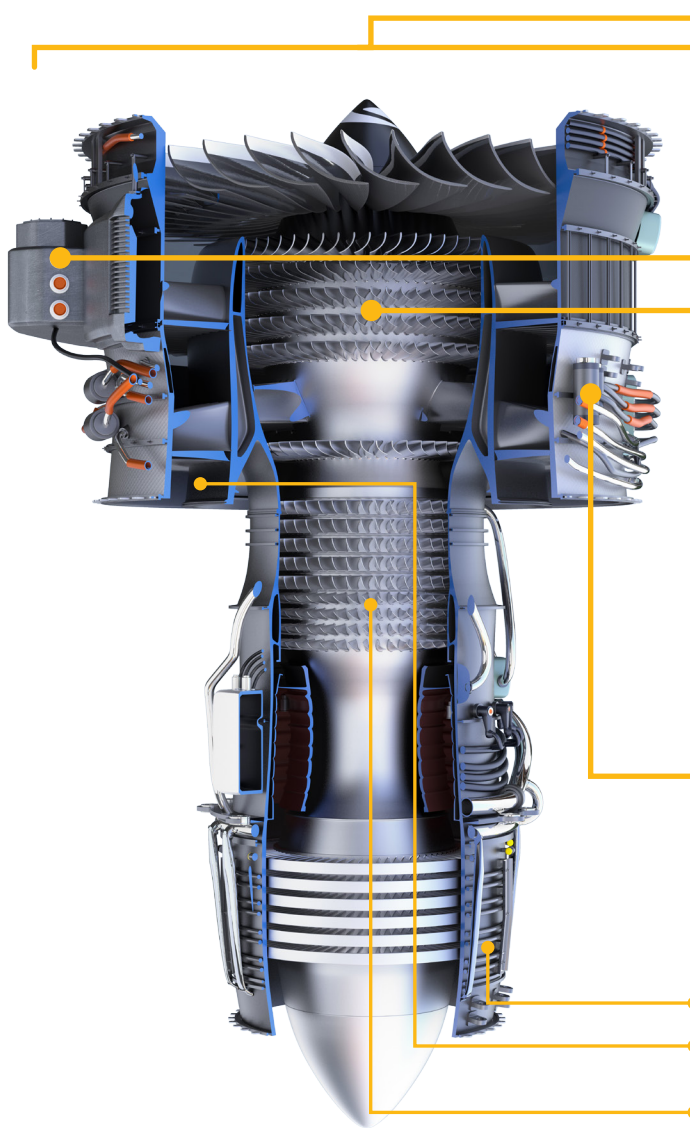

Aircraft Engines



Lubricants designed specifically for aircraft engines to improve the functionality, reliability and longevity of components from take-off to landing.



STRUCTURAL CONNECTIONS (PINS, BOLTS & BUSHINGS)

Thread, Spline & Coupling - Rheolube® 733MZ
Trunnion Pin & Pivots - Rheolube® 374A

ACCESSORY DRIVE COMPONENTS

**Engine Driven Generators & Compressors
(High-Speed Bearings)** - Rheoplex 6000HT
Fuel Pumps - UniFlor™ 8921
Starter (Gearbox) - Rheolube® 377AL

O-RINGS & SEALS

Fuel Valve O-Ring & Seals - UniFlor™ 8921
Hydraulic O-Ring & Seals - UniFlor™ 8512S
Shaft Seals - UniFlor™ 8961MT

ELECTRICAL & SENSOR SYSTEMS

Sensors, Connectors & Wiring Harnesses - UniFlor™ 8917

ACTUATOR BEARINGS & MECHANISMS

Exhaust & Thrust Mechanisms - UniFlor™ 8961MT & UniFlor™ 8991MT
Fuel Control - UniFlor™ 8921, UniFlor™ 8951, UniFlor™ 8980,
UniFlor™ 8981 & Rheoplex 6000HT
Start Control & Compressor Valves - UniFlor™ 8961MT & UniFlor™ 8991MT

LUBRICANTS IN FLIGHT: ENGINE

Aircraft engines operating at high altitudes must withstand a wide range of temperatures. Components must be compatible with aviation fuels and resist corrosive fuel system vapors. Unique fluorinated synthetic lubricants that are inherently inert are ideal for this kind of operating environment. In addition to staying fluid at very low temperatures of -90°C, their superior thermo-oxidative stability prevents high-temperature oxidation and varnishing even at continuous temperatures of 250°C, while also resisting aggressive chemicals and fuels.

